

WHEEL LOADER**TL 210****Specifications:**

Operating Weight	27,558 lbs (12,500 kg)
Net Engine Power	162 hp (119 kW)
Bucket Capacities	2.5 - 4.5 yd ³ (1.9 - 3.4 m ³)
Drawbar Pull	23,625 lbs (10,500 daN)

Features:

- New hydrotransmatic drive provides the high speed, low torque effort when you are traveling across a jobsite, then changes to high torque, low speed when you demand greater traction and more power.
- Terex TSP (Terex Special Parallel) modified parallel linkage provides the breakout force of traditional Z-bar linkage and the superior load leveling and visibility of parallel lift systems.
- Transverse mounted Cummins QSB 6.7 Turbo-charged diesel engine provides added power as well as additional counterweight to the rear of the machine for improved operator performance.
- Oscillating rear axle provides stable operation on uneven ground while maintaining 4-wheel traction for greater operator comfort and control.
- Single pin articulated joint provides a more stable platform and less need for adjusting and maintenance.
- Dynamic braking is achieved through the hydrostatic drive for increased brake life.



Standard Equipment

Operating Data, Standard Equipment*

Operating weight (ISO 6016)	27,558 lbs (12,500 kg)
Tipping load, straight at full reach	19,613 lbs (8,895 kg)
Tipping load, articulated at full reach	17,397 lbs (7,890 kg)
Operating load, fully articulated	8,699 lbs (3,945 kg)
Total length, bucket on ground	23' 3" (7,095 mm)
Total width	8' 2" (2,500 mm)
Turning radius at outside bucket edge	19' 7" (5,970 mm)
Wheelbase	10' 2" (3,100 mm)
Total height (top of cab)	10' 8" (3,260 mm)

Engine

Manufacturer, model	Cummins, QSB 6.7
Type	6-cylinder, turbocharged diesel engine, COM III/EPA III
Combustion	4-stroke, common rail injection
Displacement	409 in ³ (6,700 cm ³)
Net power rating at 2200 rpm (ISO 9249)	162 hp (119 kW)
Cooling system	Water

Electrical System

Nominal voltage	24 V
Battery	2 x 12V / 105 Ah / 760 A

Power Transmission

Hydrostatic drive, closed circuit, independent from loader hydraulics. Automatic adjustment of drawbar pull and speed. Hydrotransmatic drive system providing automatic shifting for two speed ranges. Infinitely variable speed control forward and reverse. 4-wheel drive from reduction gear on rear axle via drive shaft to front axle. Combination braking, inching pedal.

2 gears:

Speed range I	0 - 3.7 mph (0-6 km/h)
Speed range II	0 - 25 mph (0-40 km/h)
Drawbar pull	23,625 lbs (10,500 daN)

Axles

Front: Rigid planetary final drive axle. Limited slip-type differential.	
Rear: Oscillating (with cushioning) planetary final drive axle, with integrated reduction gear. Limited slip-type differential.	
Oscillation	±12°

Steering

Standard	20.5-25 EM 60 12 PR
----------	---------------------

Brakes

Service brake: Hydraulically actuated two-circuit power brake system. Oil-immersed multi-disc brakes in both axles, acting on all 4 wheels via 4-wheel drive.

Auxiliary brake: Hydrostatic drive provides dynamic braking.

Parking brake: Spring-loaded brake acting on multi-disc brakes on both axle shafts.

Steering

Articulated, 2 steering cylinders with final positioning damping on both sides, fully hydraulic through Load-Sensing priority valve, quick and easy steering even at engine idle-running speed.

Total steering angle	80°
----------------------	-----

Fluid Capacities

Fuel tank	63 gal (240 L)
Hydraulic system (includes tank)	35.6 gal (135 L)

Hydraulic System

Maximum pump capacity	42.3 gpm (160 Lpm)
Maximum working pressure	3,916 psi (270 bar)

Control unit: Proportional hydraulic valve with 3 control circuits. Simultaneous, independent control of all movements. Single, four-way control lever (multi-function lever) for 1 tilt and 2 lift cylinders with integrated travel direction selector switch and switch for additional control circuit. Float position in control circuit "Lowering", electrohydraulically operated. Additional control circuit electrically operated with preselection of flow rate and Impulse/Continuous Operation.

Loader Frame

Loader frame with TSP-linkage, attachments directly mounted. Optional hydraulic quick-mount hitch (QMH) or JRB Style Quick Coupler available.

General-purpose bucket (ISO 7546)	2.75 yd ³ (2.1 m ³)
Lift capacity at ground level (ISO 14397-2)	27,740 lbs (123,400 N)
Breakout force at bucket edge (ISO 14397-2)	23,830 lbs (106,000 N)

Fork Lift Attachment*

Payload over the total lift and steering range	9,921 lbs (4,500 kg)
Payload in transport position, approx. 12" (300 mm) above ground level, total steering range	11,023 lbs (5,000 kg)
Width of fork carrier	6' 3" (1,900 mm)
Length pallet forks (5.9 x 2.4 in / 150 x 60 mm)	3' 8" (1,200 mm)
Stability factor on level & solid ground	1.25

Dimensions: General Purpose Bucket

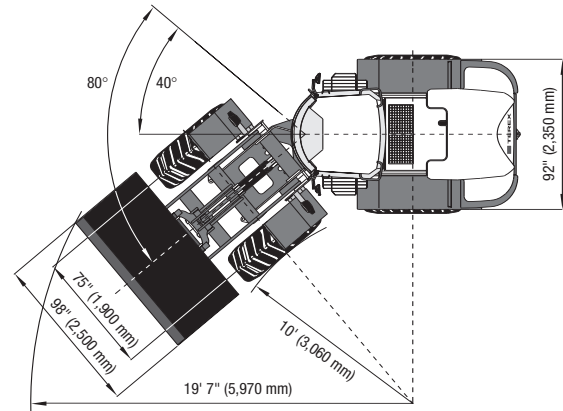
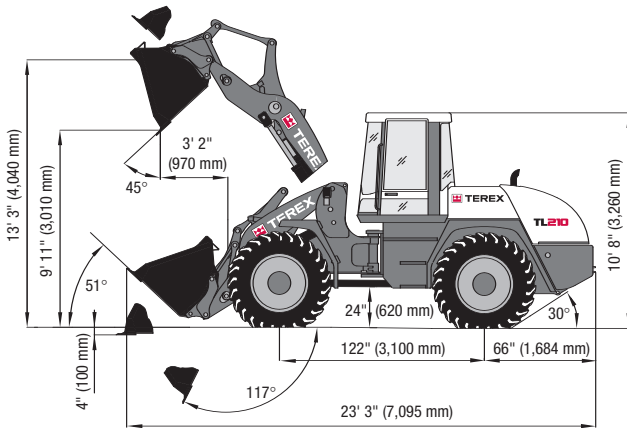

Fork Lift Attachment

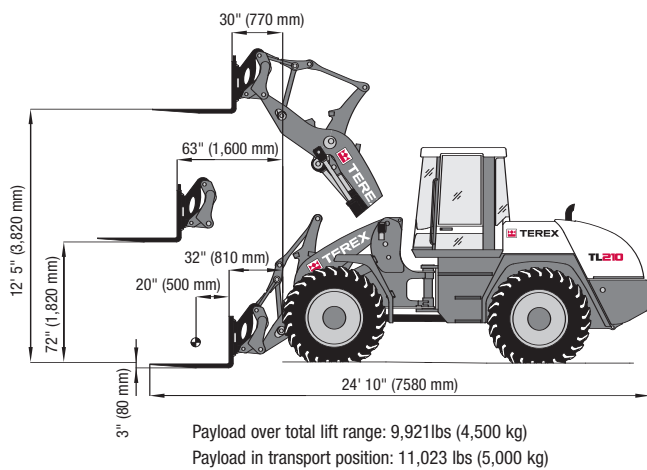

Multi-Purpose Bucket

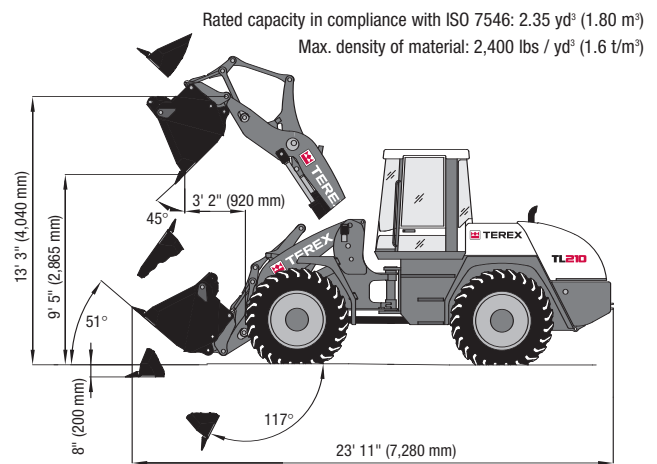

Bucket Type

	Width	Capacity	Product Code
General purpose bucket with bolt-on edge, Direct Mount	100" (2,550 mm)	2.75 yd ³ (2.10 m ³)	18TL210B28GGPW1
General purpose bucket with bolt-on edge, QMH Mount	100" (2,550 mm)	2.75 yd ³ (2.10 m ³)	18TL210B28GPCW1
General purpose bucket with bolt-on edge, JRB Style Mount	100" (2,550 mm)	2.75 yd ³ (2.10 m ³)	18TL210B28GPCC1
Light material bucket with bolt-on edge, Direct Mount	110" (2,550 mm)	4.50 yd ³ (3.44 m ³)	18TL210B45LMPW1
Light material bucket with bolt-on edge, QMH Mount	110" (2,550 mm)	4.50 yd ³ (3.44 m ³)	18TL210B45LMCW1
Light material bucket with bolt-on edge, JRB Style Mount	110" (2,550 mm)	4.50 yd ³ (3.44 m ³)	18TL210B45LMCC1
Multi-purpose bucket with bolt-on edge, Direct Mount	100" (2,550 mm)	2.25 yd ³ (1.72 m ³)	18TL210B23MPPW1
Multi-purpose bucket with bolt-on edge, QMH Mount	100" (2,550 mm)	2.25 yd ³ (1.72 m ³)	18TL210B23MPCW1
Multi-purpose bucket with bolt-on edge, JRB Style Mount	100" (2,550 mm)	2.25 yd ³ (1.72 m ³)	18TL210B23MPCC1

QMH = Quick-Mount Hitch

Examples of Material Densities

Earth (top soil)	2,550 lbs/yd ³	Clay (dry), Clay & Gravel (wet), Earth with Sand & Gravel	3,100 lbs/yd ³
Earth (dry)	2,650 lbs/yd ³	Gravel (sandy), Gravel (wet)	3,700 lbs/yd ³
Earth (moist), Clay with Gravel (dry)	3,000 lbs/yd ³	Clay (natural bed), Clay (wet)	3,500 lbs/yd ³
Earth (compacted), Gravel (dry)	3,000 lbs/yd ³		

Standard Equipment

Operator Station

Rubber-mounted full-vision steel cab, ROPS (acc. to ISO 3471) and FOPS (acc. to ISO 3449) certified.
Cab featuring two doors, electric windshield intermittent wipers and washer (front and rear), tinted panoramic safety glass, sliding window on left-hand side.
Driver's seat with hydraulic cushioning and lap belt, weight-adjustable, in compliance with ISO 7096 and ISO 6683.
Cab heating with 3-speed heater fan (choice fresh air/recirculating air) and windshield defroster, front and rear.
Automatic climate control.
Tilt and height adjustable steering wheel.
Radio pre-installation.
Noise emission ambience LWA / cab LpA 105 dBa / 75 dBa

Optional Equipment

Cab

Right-hand door with sliding window
Yellow beacon
Radio installation kit
Pressurized cabin
Independent diesel heating with timer
Fire extinguisher

Operators Stand

Air-cushioned driver's comfort seat with orthopedic lumbar support and adjustable armrests and headrest

Opt. Attachments / Accessories

Hydraulic Quick Attach

Quick-Mount Hitch (QMH)
JRB Style Class 3

Tires

20.5 R 25 XTLA TL Michelin
20.5 R 25 XHA TL Michelin
20.5 R 25 XLDD2A Michelin
20.5 R 25 XMine D2 Michelin
20.5-25 EM 12 PR SGLD Goodyear
20.5 R 25 RL-2 Goodyear
20.5 R 25 GP-2B Goodyear

Further Options

Filling with biodegradable hydraulic oil / Ester Base BIO-E-HYD-HEES
Ride control system
Back-up alarm for reverse travel
Electric refueling pump
Immobilizer (anti-theft device)
Quick couplers (flat face) for 3rd control circuit on lift frame
Pilot-controlled hose-rupture valves for lift and tilt cylinders
Fork lift attachment with forks

Further attachments available on request.

Effective Date: January, 2008. Product specifications and prices are subject to change without notice or obligation. The photographs and/or drawings in this document are for illustrative purposes only. Refer to the appropriate Operator's Manual for instructions on the proper use of this equipment. Failure to follow the appropriate Operator's Manual when using our equipment or to otherwise act irresponsibly may result in serious injury or death. The only warranty applicable to our equipment is the standard written warranty applicable to the particular product and sale and Terex makes no other warranty, express or implied. Products and services listed may be trademarks, service marks, or trade names of Terex Corporation and/or its subsidiaries in the USA and other countries. All rights are reserved. Terex is a registered trademark of Terex Corporation in the USA and many other countries. © 2008 Terex Corporation.

Terex Construction Americas
 8800 Rostin Road, Southaven, MS 38671 U.S.A.
 Tel +1 (662) 393-1800 Fax +1 (662) 393-1700
 Email sales@terexca.com
 www.terex.com
 www.terexca.com

