

Tractor Loader Backhoe

OPERATING WEIGHT	15,964 lbs (7,241 kg)
NET ENGINE POWER	94 hp (70.3 kW)
DIG DEPTH (STD)	14' 8" (4.46 m)
DIG DEPTH (EXT)	19' 3" (5.86 m)



TRACTOR LOADER BACKHOE
TX860B

Specifications

Engine	
Manufacturer, model	Perkins, Model 1104C-44TH
Induction	Turbo
Gross power rating @ 2,200 rpm (SAE J 1995)	100 hp (74.8 kW)
Net power rating @ 2,200 rpm (SAE J 1349)	94 hp (70.3 kW)
Net torque @ 1,400 rpm (SAE J 1349)	290 lbf (395 Nm)
Displacement	269 in ³ (4.4 L)
Tier-2 1100 Series with reduced noise and lower exhaust emissions. Electric fuel lift pump for increased reliability. Easy service EcoPlus fuel filters. Service periods at 500 hours. Integrated closed circuit breather further reduces emissions. Key stop/start. Two-stage dry air cleaner.	
Electrical System	
Alternator (100 amp on A/C units)	75 A
Battery (single)	770 CCA, 115 amp/hr -12 V
Battery (double)	590 CCA - each, 72 amp/hr -12 V
Battery step-mounted for good access. Low maintenance battery. Connectors sealed against water and dust. 33 circuit fuses. 25 circuit relays.	

Transmission & Ground Speeds

Carraro transmission. Fully synchronized power shuttle gearbox with 4 speeds forward and 4 speeds reverse. Single-stage torque converter with 3.01:1 stall ratio. Fast, smooth gear changes on the move. High transport speed reduces highway travel times. High tractive effort in first and second gears for high loader performance. Modulated forward and reverse clutch packs enable smooth direction changes. Front console switch allows effortless engagement of 4WD.

Travel speeds 12.5/80x18 10 ply front tires and 19.5x24 10 ply rear tires:

Gear	Forward and Reverse			
	1	2	3	4
mph	3.30	5.31	11.66	23.29
km/h	5.31	8.54	18.77	37.49

Full Powershift transmission optional. Single-stage torque converter with 2.60:1 stall ratio. Soft shift direction changes. Automatic up-shifting by selecting 4th gear. Kick-down button is standard.

Turning Circle (4WD)

	Over tires	Over bucket
Without brakes	25' 3" (7.7 m)	35' 1" (10.7 m)
With brakes	22' 3" (6.8 m)	32' 10" (10.0 m)

Specifications

Axles

	Front	Rear
Static loading rating	28,300 lbs (12,863 kg)	32,498 lbs (14,772 kg)
SAE J 43	13,655 lbs (6,207 kg)	13,541 lbs (6,155 kg)
Outboard planetary final drives for easier servicing. Foot-actuated differential lock for ease of operation. 16° front axle oscillation to maintain maximum ground contact and traction.		

Brakes

Long life sealed wet disk brakes. Self-equalizing and self-adjusting. Friction area per brake assembly 113 in² (728 cm²). Selectable 2 or 4 wheel braking.

Fluid Capacities

Fuel tank	34.2 gal (130 L)
Engine coolant	4.2 gal (16 L)
Engine oil (including filter)	2.2 gal (8.5 L)
Transmission	4.0 gal (15 L)
Rear axle (4WD)	4.6 gal (17.5 L)
Front axle (4WD)	3.3 gal (12.5 L)
Hydraulic system	37.6 gal (143 L)

Hydraulic System

Main pump @ 2,200 rpm	21 gpm (80 Lpm)
Secondary pump @ 2,200 rpm	21 gpm (80 Lpm)
System main relief setting	3,250 psi (225 bar)
Unloader settings	3,000 psi (207 bar)

Closed center system incorporating load-sensing and flow-sharing. Twin gear pumps for reliability. Power Boost to match digging power and speed to application. Automatic or manually activated to give more precise control as required. Single pedal operation of auxiliary circuit and extending dipper (optional). Hydraulic oil cooler reduces operating temperatures and tilts forward for easy cleaning. Hydraulic tank and filter easily accessed from ground level. Commercial hydraulic pumps. Rexroth hydraulic valves. Pacoma hydraulic cylinders.

Cab (Optional)

TIM cab. Wide opening doors with steps and large grab rails. Large windows, lowline curved hood and full depth rear window enhance all-around visibility. Door windows can be partially or fully opened for ventilation. Raised rear window provides ventilation and protection from the rain. Backlit, touch-operated switches. Adjustable tilt steering wheel. Two front and rear defrosting vents. Powerful 3-speed heater with two forward and three rear vents. Adjustable rear working lights.

Noise emission ambient LWA	78 dB (A)
----------------------------	-----------

Air conditioning option available.

Four-post, open-ROPS as standard equipment.

Pilot control option available for backhoe controls.



Weight Configurations

Total machine weight	15,964 lbs (7,241 kg)
Add/delete the following weights to the base machine:	
7-in-1 Multi-Purpose	+ 726 lbs (330 kg)
7-in-1 Multi-Purpose Fork Kit	+ 330 lbs (150 kg)
Deep Dig Dipper	+ 477 lbs (217 kg)
2WD	- 176 lbs (80 kg)
ROPS Frame	- 422 lbs (192 kg)
Front Counterweight	+ 605 lbs (275 kg)

Loader Dimensions

	Standard Bucket	7-in-1 Bucket
Dump clearance at 45°	8' 9" (2.68 m)	8' 9" (2.68 m)
Dump height (fully dumped)	8' 6" (2.60 m)	8' 6" (2.60 m)
Load over height	10' 9" (3.28 m)	10' 9" (3.28 m)
Hinge pin height	11' 7" (3.52 m)	11' 7" (3.52 m)
Pin forward reach	1' 2" (352 mm)	1' 2" (352 mm)
Reach at ground	5' 5" (1.65 m)	5' 5" (1.65 m)
Max. reach at full height	4' 3" (1.28 m)	4' 3" (1.28 m)
Reach at full height - 45°	2' 9" (829 mm)	2' 9" (829 mm)
Reach at full height fully dumped	2' 1" (645 mm)	2' 1" (645 mm)
Dig depth	7" (186 mm)	7" (186 mm)
Rollback at ground	45°	45°
Maximum dump angle	57°	57°
Overall operating height	13' 9" (4.20 m)	13' 11" (4.25 m)

Loader Performance

	Standard Bucket	7-in-1 Bucket
Bucket breakout	12,291 lbf (5,575 kgf)	12,114 lbf (5,495 kgf)
Arms breakout	10,917 lbf (4,952 kgf)	11,649 lbf (5,284 kgf)
Lift capacity to full height	8,783 lbf (3,984 kgf)	7,921 lbf (3,593 kgf)

Working Ranges

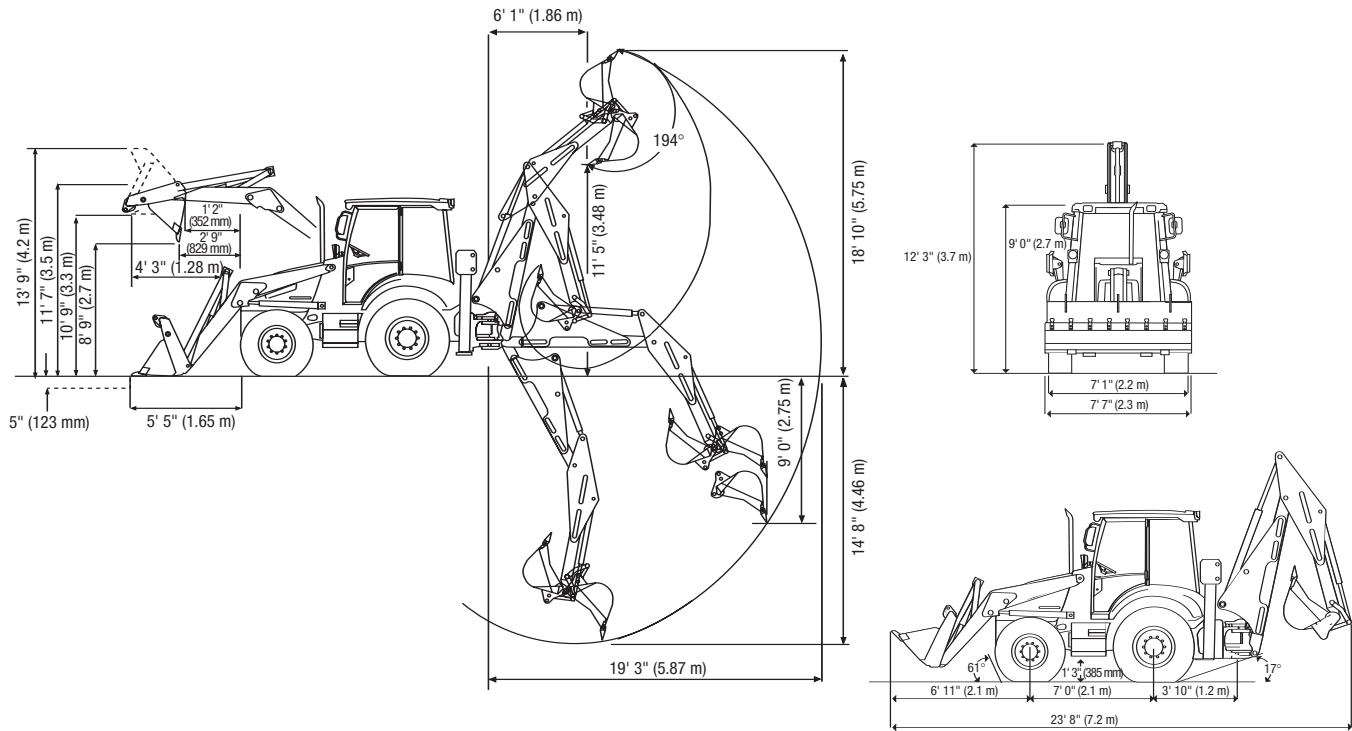

Backhoe Dimensions

	Standard Dipper	Deep Dig Dipper (Ret.)	Deep Dig Dipper (Ext.)
Dig depth SAE	14' 8" (4.46 m)	14' 8" (4.46 m)	19' 3" (5.86 m)
2 ft flat bottom SAE	14' 7" (4.45 m)	14' 7" (4.45 m)	19' 0" (5.80 m)
Reach ground level to swing post	19' 3" (5.87 m)	19' 3" (5.87 m)	23' 5" (7.14 m)
Loading reach	6' 1" (1.86 m)	6' 1" (1.86 m)	9' 2" (2.79 m)
Operating height	18' 10" (5.75 m)	18' 10" (5.75 m)	22' 1" (6.73 m)
Loading height SAE	11' 5" (3.48 m)	11' 5" (3.48 m)	14' 8" (4.46 m)
Maximum load height	12' 3" (3.74 m)	12' 3" (3.74 m)	15' 6" (4.72 m)
Maximum straight wall dig depth	9' 0" (2.75 m)	9' 0" (2.75 m)	13' 6" (4.11 m)
Bucket rotation			
Speed	194°	194°	194°
Power	163°	163°	163°
Side reach from stabilizers	12' 10" (3.91 m)	12' 10" (3.91 m)	17' 0" (5.18 m)
Stabilizer spread	11' 3" (3.43 m)	11' 3" (3.43 m)	11' 3" (3.43 m)
Maximum leveling angle	15°	15°	15°
Backhoe Performance			
Swing torque	11,875 lbf-ft (16,100 Nm)	11,875 lbf-ft (16,100 Nm)	11,875 lbf-ft (16,100 Nm)
Dipper tearout	8,329 lbf (3,778 kgf)	8,329 lbf (3,778 kgf)	5,580 lbf (2,531 kgf)
Bucket tearout			
Speed	11,636 lbf (5,278 kgf)	11,636 lbf (5,278 kgf)	11,636 lbf (5,278 kgf)
Power	14,445 lbf (6,552 kgf)	14,445 lbf (6,552 kgf)	14,445 lbf (6,552 kgf)

Tractor Loader Backhoe TX860B

Attachments / Accessories

Loader Attachments		
	Standard Bucket	7-in-1 Bucket
Width	7' 7" (2.31 m)	7' 7" (2.31 m)
Capacity	1.32 yd ³ (1.0 m ³)	1.32 yd ³ (1.0 m ³)
Weight	880 lbs (400 kg)	1,606 lbs (730 kg)
	High Capacity Bucket	High Capacity 7-in-1 Bucket
Width (Optional)	7' 10" (2.39 m)	7' 10" (2.39 m)
Capacity	1.56 yd ³ (1.2 m ³)	1.56 yd ³ (1.2 m ³)
Weight	946 lbs (430 kg)	1,687 lbs (767 kg)

Hydraulic Hammer
Sound-insulated. Tools: Moil point or chisel point

Forks (Bucket Mounted)		
	Standard Bucket	7-in-1 Bucket
Fork length	3' 6" (1.07 m)	3' 6" (1.07 m)
Section width	3" (80 mm)	3" (80 mm)
Assembly weight	330 lbs (150 kg)	330 lbs (150 kg)
Max. operating height	10' 2" (3.09 m)	10' 2" (3.09 m)
Reach at ground level	8' 10" (2.71 m)	8' 10" (2.70 m)
Reach at full height	7' 4" (2.23 m)	7' 5" (2.25 m)
S.W.L. at 20" load center	2,204 lbs (1,000 kg)	2,204 lbs (1,000 kg)

Backhoe Lifting Performance

Bucket Pin HT		BOOM LIFT			DIPPER LIFT			CRANING LIFT		
Above/Below lbs (kg)		Extending			Extending			Extending		
Ground	Std	Ret	Ext	Std	Ret	Ext	Std	Ret	Ext	
+18'	-	-	-	-	-	-	-	-	-	2,840 (1,288)
+16'	-	-	-	-	-	2,346 (1,064)	-	-	-	2,840 (1,288)
+14'	3,532 (1,602)	3,250 (1,474)	2,134 (968)	3,814 (1,730)	3,752 (1,701)	2,152 (976)	4,314 (1,956)	4,295 (1,948)	2,813 (1,276)	
+12'	*3,593 (1,629)	3,269 (1,482)	2,231 (1,012)	3,404 (1,544)	3,131 (1,420)	1,995 (904)	3,999 (1,813)	3,909 (1,773)	2,791 (1,266)	
+10'	*3,377 (1,531)	*3,153 (1,430)	2,200 (997.9)	3,307 (1,500)	2,932 (1,329)	1,896 (860)	3,924 (1,779)	3,873 (1,756)	2,791 (1,266)	
+8'	*3,201 (1,451)	*2,976 (1,349)	*2,165 (982)	3,466 (1,572)	3,051 (1,383)	1,995 (904)	4,469 (2,027)	4,417 (2,003)	3,268 (1,482)	
+6'	*3,071 (1,393)	*2,844 (1,290)	*2,097 (951.2)	4,012 (1,819)	3,638 (1,650)	2,385 (1,081)	3,955 (1,794)	3,909 (1,773)	2,892 (1,311)	
+4'	*2,989 (1,355)	*2,765 (1,254)	*2,055 (932.1)	-	-	2,914 (1,321)	-	-	3,713 (1,684)	
+2'	*2,963 (1,344)	*2,736 (1,241)	*2,041 (925.8)	-	-	3,876 (1,758)	-	-	4,301 (1,950)	
0	*2,989 (1,355)	2,740 (1,242)	2,033 (922.2)	-	-	4,398 (1,994)	-	-	4,967 (2,253)	
-2'	3,053 (1,384)	2,707 (1,227)	2,019 (915.8)	-	-	-	-	-	-	
-4'	2,989 (1,355)	2,782 (1,261)	2,019 (915.8)	-	-	-	-	-	-	
-6'	3,038 (1,378)	2,859 (1,296)	1,997 (905.8)	-	-	-	-	-	-	
-8'	3,239 (1,469)	2,859 (1,296)	2,341 (1,061)	-	-	-	-	-	-	
-10'	-	2,919 (1,324)	2,615 (1,186)	-	-	-	-	-	-	

1. Lift capacities shown are 87% of maximum lift force per SAE definition J31 and are not stability limited unless marked with an (*).

2. Figures stated apply within 90° either side of machine.

3. Figures stated are determined by static tests and do not include dynamic factors.

4. Figures stated are without bucket fitted.

5. Boom is angled at 78° for dipper lift capacities.

6. Loader bucket is on ground.

7. Crane capacity determined with hydraulic boom lock-up feature selection.



Terex Construction Americas

8800 Rostin Road
Southaven, MS 38671
USA

TEL 662-393-1800
SALES 866-837-3923
PARTS & TECH SUPPORT 888-201-6008
FAX 662-393-1700
EMAIL sales@terexca.com
WEB terexca.com

For more information, product demonstration, or details on purchase, lease and rental plans, please contact your local Terex Distributor.